

Overview and Identification

The BAPI-Stat 4 “X-Combo” (BA/BS4XC) Room Unit features 4 output channels and optional local indication of temperature and humidity. Additional options include Temperature Setpoint, Humidity Setpoint and Local Override. The optional LCD shows room temperature in °C or °F and room humidity in %RH. In addition, the unit has adjustable offsets for both temperature and humidity and is capable of having the range for the temp., humidity and setpoints changed in the field.

The unit has 4 output channels. Channel 1 and 2 can be ordered as voltage or current, channel 3 as voltage or resistance and channel 4 as a passive temperature sensor or isolated override contact.

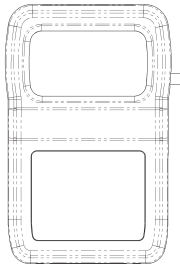

Fig. 2: Unit with Override but No Display or Setpoint

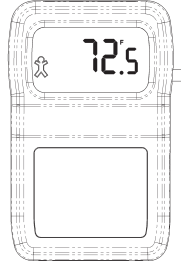

Fig. 3: Unit with Override and Display but No Setpoint

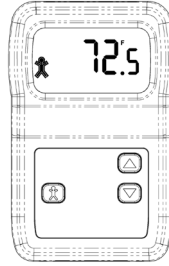

Fig. 4: Unit with Override, Display and Setpoint

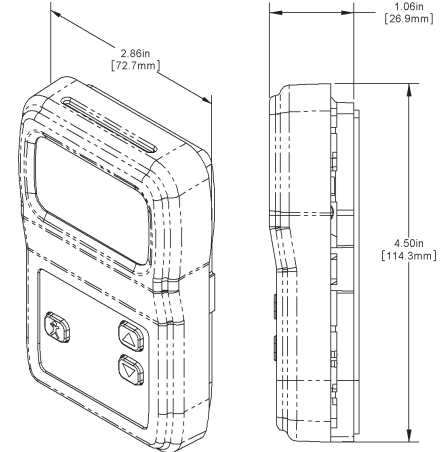

Fig. 1: BAPI-Stat 4 X-Combo Dimensions

Mounting

JUNCTION BOX

1. Pull the wire through the wall and out the junction box, leaving about six inches free. Pull the wire through the hole in the base plate.
2. Secure the base to the box using the #6-32 x 5/8 inch mounting screws provided.
3. Terminate the unit according to the guidelines in the **Termination** section.
4. Attach Cover by latching it to the top of the base, rotating the cover down and snapping it into place.
5. Secure the cover by backing out the lock-down screws using a 1/16” Allen wrench until they are flush with the bottom of the cover.

DRYWALL MOUNTING

1. Place the base plate against the wall where you want to mount the sensor. Mark the two mounting holes and the area where the wires will come through the wall.
2. Drill two 3/16” holes in the center of each marked mounting hole. Insert a drywall anchor into each hole.
3. Drill one 1/2” hole in the middle of the marked wiring area. Pull the wire through the wall and out of the 1/2” hole, leaving about six inches free.
4. Pull the wire through the hole in the base plate.
5. Secure the base to the drywall anchors using the #6 x 1 inch mounting screws provided.
6. Terminate the unit according to the guidelines in the **Termination** section.
7. Attach Cover by latching it to the top of the base, rotating the cover down and snapping it into place. Secure the cover by backing out the lock-down screws using a 1/16” Allen wrench until they are flush with the bottom of the cover.

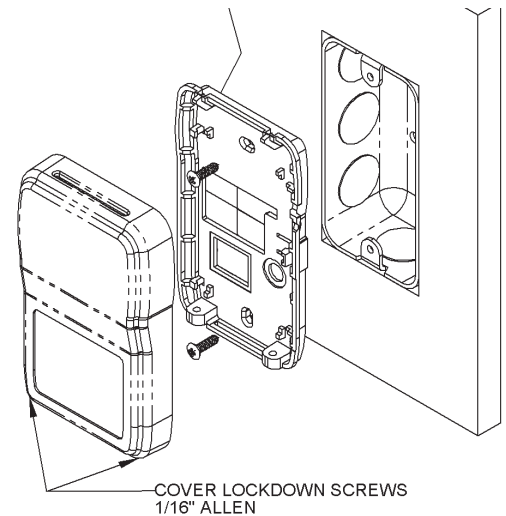

Fig. 5: Mounting hardware is provided for both junction box and drywall installation (junction box installation shown).

NOTE: In a wall-mount application, the mixing of room air and air from within the wall cavity can lead to erroneous readings, condensation, and premature failure of the sensor. To prevent this condition, plug the conduit hole with insulation in the junction box.

Termination

BAPI recommends using twisted pair of at least 22AWG and sealant filled connectors for all wire connections. Larger gauge wire may be required for long runs. All wiring must comply with the National Electric Code (NEC) and local codes. Do NOT run this device's wiring in the same conduit as AC power wiring. BAPI's tests show that fluctuating and inaccurate signal levels are possible when AC power wiring is present in the same conduit as the signal lines. If you are experiencing any of these difficulties, please contact your BAPI representative.



BAPI recommends wiring the product with power disconnected. Proper supply voltage, polarity, and wiring connections are important to a successful installation. Not observing these recommendations may damage the product and will void the warranty.

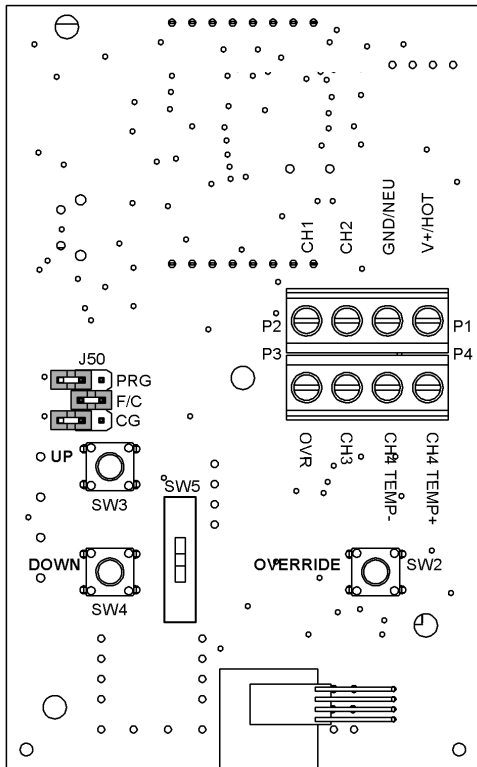

Fig. 6: X-Combo Circuit Board

Terminal Description

- GND/NEU** Power Supply Common Ground (Ground to the Controller)
- V+/HOT** Power Supply Hot (See specifications for voltage details)
- CH1** Ch. 1 Signal, Voltage or 4 to 20mA*, referenced to Common Ground
- CH2** Ch. 2 Signal, Voltage or 4 to 20mA*, referenced to Common Ground
- CH3** Ch. 3 Signal, Voltage or Resistance, referenced to Common Ground
- CH4 TEMP+** Channel 4 + Signal, Passive Temp Sensor and/or Override Contact, referenced to "CH4 TEMP -" (**See "Grounding Note" below)
- CH4 TEMP-** Channel 4 - Signal, Passive Temp Sensor and/or Override Contact (**See "Grounding Note" below).
- OVR**..... Override input to turn on the Occupied BAPI-Man on the Display, referenced to Common Ground

*4-20mA Note:

This current output is NOT a loop powered output. It sources the power for the loop per the specification.

**Grounding Note:

Common Ground (-CG) or Differential Ground (-DF) are selected per order but can be changed in the field (see Optional Technician Adjustments section). In -DF Mode, the "CH4 TEMP-" and "CH4 TEMP+" terminals are isolated from the rest of the sensor. In -CG Mode, the "CH4 TEMP-" terminal is internally connected to the power ground terminal GND/NEU.

Circuit Board Note: If a display unit is ordered with Setpoint Adjustment, then Switches 3 & 4 will NOT be present on the BACK of the circuit board. If a display unit is ordered with Override, then Switch 2 will NOT be present on the back of the circuit board.

Channel Terminal Name	Output Variable					Output Type			
	Temp	Humidity	Temp Setpoint	Humidity Setpoint	Override	Voltage	Current Sourcing	Resistive	592/334
CH1	X		X	X	X	X	X		
CH2		X	X	X	X	X	X		
CH3			X	X	X	X		<50KΩ	
CH4 TEMP +	X				X			Sensor	V +
CH4 TEMP -	X				X			Sensor	V -

Specifications subject to change without notice.

Optional Communication Jack Wiring

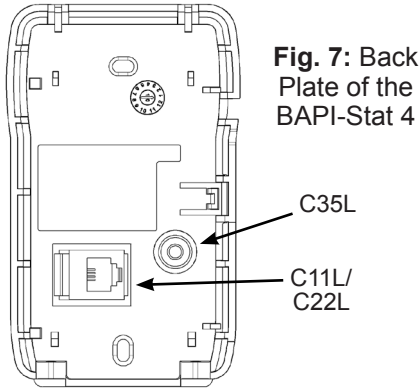
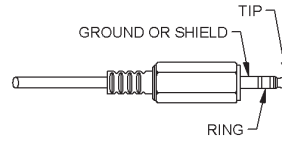

Fig. 7: Back Plate of the BAPI-Stat 4

Fig. 8: C35L Comm. Jack (male jack shown for clarity)



C35L Wiring	
	Wire Color
Ground	Black
Tip	White
Ring	Red

Fig. 9: C11L/C22L Comm. Jack

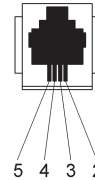

C11L/C22L Wiring	
Comm Jack Pin	Wire Color
1	Not Connected
2	Black
3	Red
4	Yellow
5	Green
6	Not Connected

Optional Test and Balance Switch (SW5)

The test and balance switch is used by the balancer to equalize the flow of air or water per the design prints. This switch can also be used by the commissioning technician to verify sensor termination in a point to point checkout of the control system. The "Run" position allows the real sensor to be monitored. The "High" position forces the output to a very hot reading and the "Low" position forces the output to a very cold output. The table below shows the most common sensor output readings.

	Low: Sets the sensor value low
	Run: Sensor operates normally
	High: Set the sensor value high

Sensor Type	Low Temp (40°F) Resistance Value	High Temp (105°F) Resistance Value
1000Ω RTD	1.02KΩ (41.20°F)	1.15KΩ (101.5°F)
3000Ω Thermistor	7.87KΩ (39.8°F)	1.5KΩ (106.8°F)
10K-2 Thermistor	30.1KΩ (34.9°F)	4.75Ω (109.1°F)
10K-3 Thermistor	26.7KΩ (35.9°F)	5.11KΩ (108.4°F)
10K-3(11K) Thermistor	7.32KΩ (43.7°F)	3.65Ω (105.2°F)

Display and Front Panel Button Operation

The "X-Combo" is available with optional LCD, override and setpoint buttons. See Fig. 10 for a fully featured sensor.

NUMERICAL DISPLAY:

The default numerical display shows current temperature, and toggles to humidity display at an adjustable rate of 1 to 20 seconds. When the up/down buttons are pushed, the display will show and adjust the current setpoint and hold that display for 3 seconds. The unit can also be programmed to "setpoint only" display or setpoint lockout. See pages 4-5.

BAPI-MAN INDICATOR (FIG. 11):

The BAPI-Man on the display indicates whether the room is in the "Occupied" (solid) or "Un-occupied" (hollow) status.

Note: The unit must receive a confirmation (ground) signal on the "OVR" terminal for the BAPI-Man to remain visible on the screen. Pressing the Override button will light the BAPI-Man indicator; however, if no confirmation signal is received, then the BAPI-Man will go blank (disappear) after 5 seconds.

Continued on next page....

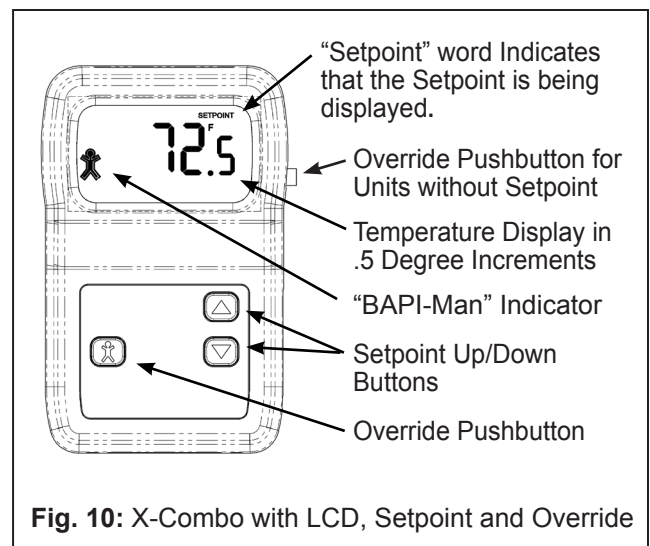
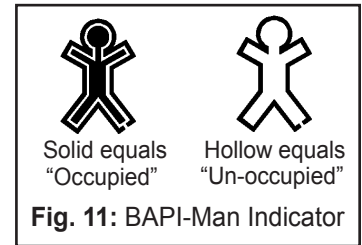

Fig. 10: X-Combo with LCD, Setpoint and Override



Display and Front Panel Button Operation continued...

Upon receiving a first confirmation (ground) signal on the "OVR" terminal, the BAPI-Man will show occupied (solid). The BAPI-Man will then show un-occupied (hollow) whenever the confirmation signal is removed and occupied when the signal is returned. The only way to blank the BAPI-Man from the display at this point is to cycle power.



VERRIDE BUTTON:

When the override button is pressed, the BAPI-Man will be displayed (solid) for 3-5 seconds and the override output will shunt or short for 5 seconds depending on the override option selected. Momentary closure of the selected channel goes to its minimum value for 5 seconds (Voltage goes to 0, 1, or 2 volts, current goes to 4mA, resistance goes to ~10Ω or the channel 4 value goes to <1Ω on terminals "CH4 TEMP+" to "CH4 TEMP-"). If an override confirmation (ground) signal is received on the "OVR" terminal, then the BAPI-Man will stay filled in, indicating an occupied status. If no confirmation signal is received, then the BAPI-Man will revert to a hollow man display, indicating an un-occupied status. (See "BAPI-Man Indicator" above for more information.)

TEMPERATURE SETPOINT:

Press the Setpoint Up/Down buttons once to enter the Setpoint Adjustment Mode. View the display to see whether you are in Temperature or %RH Setpoint mode. If needed, press the Override Button once to toggle to Temperature Setpoint mode. The current temperature setpoint will display for 5 seconds. When the Setpoint Up/Down buttons are pressed in this mode, the temperature setpoint will change in one degree increments. It will only change within the setpoint range that was ordered. After 5 seconds of no buttons being pushed, the sensor will go into the standard display or toggle mode.

%RH SETPOINT:

Press the Setpoint Up/Down buttons once to enter the Setpoint Adjustment Mode. View the display to see whether you are in Temperature or %RH Setpoint mode. If needed, press the Override Button once to toggle to the %RH Setpoint Adjustment Mode. The current %RH Setpoint will display for 5 seconds. Pressing the UP/Down buttons will change the selected setpoint by 1% increments. After 5 seconds of no buttons being pushed, the sensor will go into the standard display or toggle mode.

Optional Technician Adjustments (The sensor set-up is factory set per your order. Set-up adjustments are not required)

The unit is shipped ready to install per the order and does not require any special setup or programming. The following Set-up or Program Menu Changes are available if the installer decides to change the factory settings. Program Menu changes require a display on the sensor. Non-display sensors must be factory configured.

Note: The Setpoint Up/Down Buttons and Override Button are used to make Menu changes. If the unit is ordered without Setpoint Adjustment or Override, then buttons will be located on the back of the PCB inside the sensor. See Figure 6 on page 2. These buttons will not be present on the PCB if the unit has been ordered with Setpoint and Override.

SET-UP JUMPER (J50) CONFIGURATION: (FACTORY SET PER ORDER)

<u>Label</u>	<u>Description</u>	<u>Setting</u>
PRG	Program Mode or Run Mode	Program Mode = Jumper installed for Program Mode (See Program Menu below) Run Mode = Jumper removed for Run Mode (Place jumper on one pin only)
F/C	°C Indication or °F Indication	°C = Jumper installed for °C Indication °F = Jumper removed for °F Indication (Place jumper on one pin only)
CG	Common Ground or Differential	Common Ground = Jumper installed for Common Ground ("CH4 TEMP-" terminal connected to ground) Differential Ground = Jumper removed for Differential Ground ("CH4 TEMP-" terminal isolated from ground)

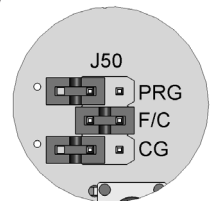

Fig. 12: J50 Jumper

Continued on next page....



Optional Technician Adjustments continued....

PROGRAM MODE MENU PAGES: (DISPLAY REQUIRED)

Note: The J50 jumper “ °F/°C “ selection determines what engineering unit is used for the following program mode. Make sure to selected the desired °F or °C before adjusting the program values below.

ENTERING PROGRAM MODE AND MAKING CHANGES:

1. Install the J50 “PRG” jumper onto both pins to enter Program Mode.
2. Press the Up/Down Buttons to advance to the desired program parameter from P1 through P17. (Parameters described below).
3. Press the Override Button to select the specific program parameter to change.
4. Change the parameter value as described in the Mode Menus section below.
5. Press the Override Button again to set the selected parameter.
6. Press the Up/Down Buttons to proceed to the next parameter (as in Step 3 above).
7. When done making changes, remove the J50 “PRG” jumper (and place over one pin) to end the programming mode and store all the values. The sensor is now in the run mode.

MODE MENUS

P1 - Display Selection (Move the Setpoint Up/Down Arrows to change the display mode. Factory default setting is “03”)

- 00 = No display (Blank)
- 01 = Temp display only
- 02 = %RH display only
- 03 = Temp and %RH display, toggling
- 04 = Temp Setpoint display only
- 05 = Temp and Temp Setpoint display, toggling
- 06 = %RH and Temp Setpoint display, toggling
- 07 = Temp, %RH and Temp Setpoint display, toggling
- 08 = %RH Setpoint only
- 09 = Temp and %RH Setpoint display, toggling
- 10 = %RH and %RH Setpoint display, toggling
- 11 = Temp, %RH and %RH Setpoint display, toggling
- 12 = Temp Setpoint and %RH Setpoint display, toggling
- 13 = Temp, Temp Setpoint and %RH Setpoint display, toggling
- 14 = %RH, Temp Setpoint and %RH Setpoint display, toggling
- 15 = Temp, %RH, Temp Setpoint & %RH Setpoint display, toggling

P2 - Display Toggle Rate (Factory default is 5 seconds)

Move the Up/Down arrows in 1 second increments up to 20 seconds between variables as selected in P1.

P3 - Temperature Span Low Limit (Factory set per order)

Move the UP/Down arrows in 1° increments between -40 to 140 span. (°F or °C must be selected first on Jumper J50.)

P4 - Temperature Span High Limit (Factory set per order)

Move the UP/Down arrows in 1° increments between -40 to 140 span. (°F or °C must be selected first on Jumper J50.)

Continued on next page....



Optional Technician Adjustments continued....

MODE MENUS Continued....

P5 - %RH Span Low Limit: (Factory set per order)

Move the UP/Down arrows in 1% increments between 0% to 100% span.

P6 - %RH Span High Limit: (Factory set per order)

Move the UP/Down arrows in 1% increments between 0% to 100% span.

P7 - Fixed Temperature Setpoint (Must be within the Temperature spans set in menu page P3 and P4.)

This function is used for Temperature Setpoint Lockout Only. Move the UP/Down arrows in 1° increments between -40 to 140 span. (°F or °C must be selected first on Jumper J50.)

P8 - Temperature Setpoint Span Low Limit (Must be within the Temp spans set in menu page P3 and P4.)

Move the UP/Down arrows in 1° increments between -40 to 140 span. (°F or °C must be selected first on Jumper J50.)

P9 - Temperature Setpoint Span High Limit (Must be within the Temp spans set in menu page P3 and P4.)

Move the UP/Down arrows in 1° increments between -40 to 140 span. (°F or °C must be selected first on Jumper J50.)

P10 -%RH Setpoint (Must be within the RH spans set in menu page P5 and P6.)

This function is used for %RH Setpoint Lockout Only. Move the UP/Down arrows in 1% increments between 0% to 100% span.

P11 -%RH Setpoint Span Low Limit (Must be within the RH spans set in menu page P5 and P6.)

Move the UP/Down arrows in 1% increments between 0% to 100% span.

P12 -%RH Setpoint Span High Limit (Must be within the RH spans set in menu page P5 and P6.)

Move the UP/Down arrows in 1% increments between 0% to 100% span.

P13 -Temperature Offset

Move the UP/Down arrows in 0.1° increments between -5 to +5 °F or °C. This affects both the display and signal output values.

P14 -%RH Offset

Move the UP/Down arrows in 0.1% increments between -5% to +5%. This affects both the display and the signal output values.

P15 -Test & Balance Channel 1:

This only applies to the active Ch. 1 output. The passive sensor must use the (-TB) option and a board mounted 3 position switch.

Move the UP/Down arrows to “+1” to output a high temp output. Move the UP/Down arrows to “0” to output the normal temp value on the output. Move the UP/Down arrows to “-1” to output a low temp output. On exit from programming mode, the active Test & Balance will no longer be active, so the output changes to the live variable.

P16 -Setpoint Lockout (Move the UP/Down arrows to change the lockout mode desired.)

00 = No Setpoint Lockout (Default)

01 = Temperature Setpoint Lockout Only. (See P7 for lockout value)

02 = Temperature Setpoint Lockout and %RH Setpoint Lockout. (See P7 and P10 for lockout value)

03 = %RH Setpoint Lockout Only. (See P10 for lockout value)

P17 -Temperature Display Resolution (Move the UP/Down arrows to change the resolution to the desired value.)

01 = .1 Degree Temperature Resolution

02 = .5 Degree Temperature Resolution (Default)

03 = 1 Degree Temperature Resolution



Diagnostics - Temperature Output

Problems:

Temperature Reading is Incorrect

Possible Solutions

- Check for proper wire terminations and determine that the temperature input is set up correctly in the controller and in the building automation software.
- Check the wiring between the sensor and controller. Label the terminals at the sensor end and the controller end. Disconnect the interconnecting wires from the controller and the sensor. With the wires disconnected, measure the resistance from wire-to-wire with a multimeter. The meter should read greater than 10 Meg-ohms, open or OL depending on the meter. Short the interconnecting wires together at one end. Go to the other end and measure the resistance from wire-to-wire with a multimeter. The meter should read less than 10 ohms (22 gauge or larger, 250 feet or less). If either test fails, replace the wire.
- Check the sensor temperature output against a reference. Measure the temperature at the sensor's location using an accurate temperature standard. Disconnect the temperature channel wires and measure the temperature signal with a multi-meter and compare to the reference temperature. For resistive output units, use the "Sensor Specs" tables in the "Resource Library" section of the BAPI website (www.bapivac.com) for the reference. For voltage or current output units, use the equations below for the reference. If the output and reference differ by more than 5%, call BAPI technical support.
- Make sure that the Test and Balance switch is in the correct position.
- Make sure that the temperature sensor element leads are not touching one another.
- Determine if the sensor is exposed to an external source different from the room environment (conduit draft). Plug the conduit or fill the handy box as necessary. DO NOT use silicon caulk.

Setpoint reading is incorrect

- Make sure that the setpoint output is correct. Remove the setpoint output wire (Channel 1, 2 or 3. See product label for configuration.) and check the output for the correct resistance, current or voltage output. Call BAPI technical support if the value doesn't match the label.

4-20mA Temperature Equation

$$T = T_{Low} + \frac{(A - 4) \times (T_{Span})}{16}$$

- T = Temperature at sensor
- T_{Low} = Low temperature of span
- T_{High} = High temperature of span
- T_{Span} = T_{High} - T_{Low}
- A = Signal reading in mA

Voltage Temperature Equation

$$T = T_{Low} + \frac{(V - V_{Low}) \times (T_{Span})}{V_{Span}}$$

- T = Temperature at sensor
- T_{Low} = Low temperature of span
- T_{High} = High temperature of span
- T_{Span} = T_{High} - T_{Low}
- V_{Low} = Low transmitter voltage usually=(0, 1 or 2v)
- V_{High} = High transmitter voltage usually=(5 or 10v)
- V_{Span} = V_{High} - V_{Low}
- V = Signal reading in volts

Diagnostics - Humidity Output

Problems:

Humidity Reading is Incorrect

Possible Solutions

- Check for proper wire terminations and determine that the humidity input is set up correctly in the controller and in the building automation software.
- Check the wiring between the sensor and controller (as described above).
- Check the sensor humidity output against a reference. Measure the humidity at the sensor's location using an accurate standard. Disconnect the humidity channel wires and measure the humidity signal with a multi-meter and compare to the reference, using the equations at right for the reference. If the output and reference differ by more than 5%, call BAPI technical support.
- Determine if the sensor is exposed to an external source different from the room environment (conduit draft). Plug the conduit or fill the handy box as necessary. DO NOT use silicon caulk.

4-20mA Humidity Equation

$$RH = RH_{Low} + \frac{(A - 4) \times (RH_{Span})}{16}$$

- RH = %RH at sensor
- RH_{Low} = Low %RH of Span
- RH_{High} = High %RH of Span
- RH_{Span} = RH_{High} - RH_{Low}
- A = Signal reading in mA

Voltage Humidity Equation

$$RH = RH_{Low} + \frac{(V - V_{Low}) \times (RH_{Span})}{V_{Span}}$$

- RH = %RH at sensor
- RH_{Low} = Low %RH of Span
- RH_{High} = High %RH of Span
- RH_{Span} = RH_{High} - RH_{Low}
- V_{Low} = Low transmitter voltage usually=(0, 1 or 2v)
- V_{High} = High transmitter voltage usually=(5 or 10v)
- V_{Span} = V_{High} - V_{Low}
- V = Signal reading in volts



BAPI-Stat 4 “X-Combo”, Room %RH and Temp. Sensor

BA/BS4XC

Installation & Operating Instructions

27939_ins_BS4XC

rev. 10/28/16

Specifications

- Supply Voltage:** 16 to 30 VDC or 18 to 30 VAC
- Supply Power:** VDC = 50mA
- Temperature Sensor:** Semiconductor Band gap, $\pm 0.5^{\circ}\text{C}$
- %RH Sensor:** 2% Accuracy from 20 to 80%, Capacitive
- Available Outputs:** 3 Configurable, 1 Passive Sensor
 - Channels 1 & 2 Voltage or Current
 - Channel 3..... Voltage or Resistance
 - Channel 4..... Passive Sensor, Dedicated override contact
- Output Signals:** Direct or reverse acting available
 - Voltage..... VDC 0 to 5V, 1 to 5V, 0 to 10V, 2 to 10V, Impedance $>10\text{K}\Omega$, (ref. to common ground)
 - Current (Sourcing) 4 to 20mA, 500Ω @11.5 VDC (referenced to common ground)
 - Resistance (Setpoint) Available on Ch. 3 Only
 - Passive Sensor (Ch. 4).... Thermistor, RTD or Solid State,
 - CG Units, “TEMP-” terminal is Common Ground,
 - DF Units, “TEMP” terminals are isolated
 - Thermistor, $\pm 0.36^{\circ}\text{F}$ ($\pm 0.2^{\circ}\text{C}$),
 - High Accuracy Thermistor [XP], $\pm 0.18^{\circ}\text{F}$ ($\pm 0.1^{\circ}\text{C}$)
 - Platinum RTD, $\pm 0.12\%$, [A] $\pm 0.06\%$
 - Nickel RTD, 1000Ω @70°F, JCI curve
 - Solid State, AD592 or LM334
- Digital Input (DI):** Occupied dry DI input (lights BAPI-Man on display)
- Program Controls:** Requires display. See “Program Mode” section
 - Offset..... Temperature or Humidity
 - Range Setup..... Temperature, Humidity or Setpoint - Limits: -40 to 140°F or $^{\circ}\text{C}$ or 0 to 100%RH
 - Display Setup Temp./%RH/Setpoint with adjustable toggle rate
 - Display Units..... $^{\circ}\text{F}$, $^{\circ}\text{C}$, %RH, Setpoint, BAPI-Man
- Field Configuration:** J50 Jumper Pins
 - Channel 4 Ground..... CG = Jumper installed, “TEMP-” is Common Ground
DF = Jumper removed, terminals Isolated (DF Mode)
 - $^{\circ}\text{F}/^{\circ}\text{C}$ Indication..... $^{\circ}\text{C}$ = Jumper installed, $^{\circ}\text{F}$ = Jumper removed
 - Program Mode..... ON = Jumper installed for Program Mode
PRG = Jumper removed for Run Mode
- Optional Faceplate Controls:**
 - Setpoint Up/Down Buttons (requires display)
 - Override (BAPI-Man)..... Momentary occupied request button (5 sec), or setpoint mode change if in Setpoint Mode
 - Test & Balance..... 3-position switch for passive sensor
- Optional Override:** Shunt on any one of 4 Channels
 - Face Button Used on Setpoint units
 - Side Button..... Used on Non-Setpoint units
- Optional Comm. Jack:** Located in base: -C11 = RJ11, 4 wires • -C35 = 3.5mm, 3 wire • -C22 = RJ22, 4 wires
- Optional Colored Plate:**..... -WMW = Warm White plate • -GRY = Gray plate
- Test & Balance:** 3 Temp. Positions: High/Run/Low
 - Active type Program Mode, Ch. 1, (Prog. page P15)
 - Passive Sensor Optional for Ch. 4 w/ 3-Way Internal Switch
- Optional Display:** LCD-Temp, RH, Setpoint, Override
 - Display size 2.04”W x 1.33”H
 - Digits..... ± 999.9 Digits @0.6”H
 - Resolution..... 0.5 displayed value, 0.1 for offset adjust
 - Units $^{\circ}\text{F}$, $^{\circ}\text{C}$, %, BAPI-Man, Setpoint
 - Value Displayed..... Always shows the value regardless of the output range
- Termination:** 8 Terminals, 16 to 22 AWG
- Mounting:** Standard 2x4” J-Box or Drywall
- Enclosure Material:** ABS Plastic, UL94V-0
- Ambient (Enclosure):** 32 to 122°F (0 to 50°C), 0 to 95% RH, Non-condensing
- Agency:** RoHS

Specifications subject to change without notice.